

# 翼（主翼・垂直尾翼・水平尾翼）

主翼（左）

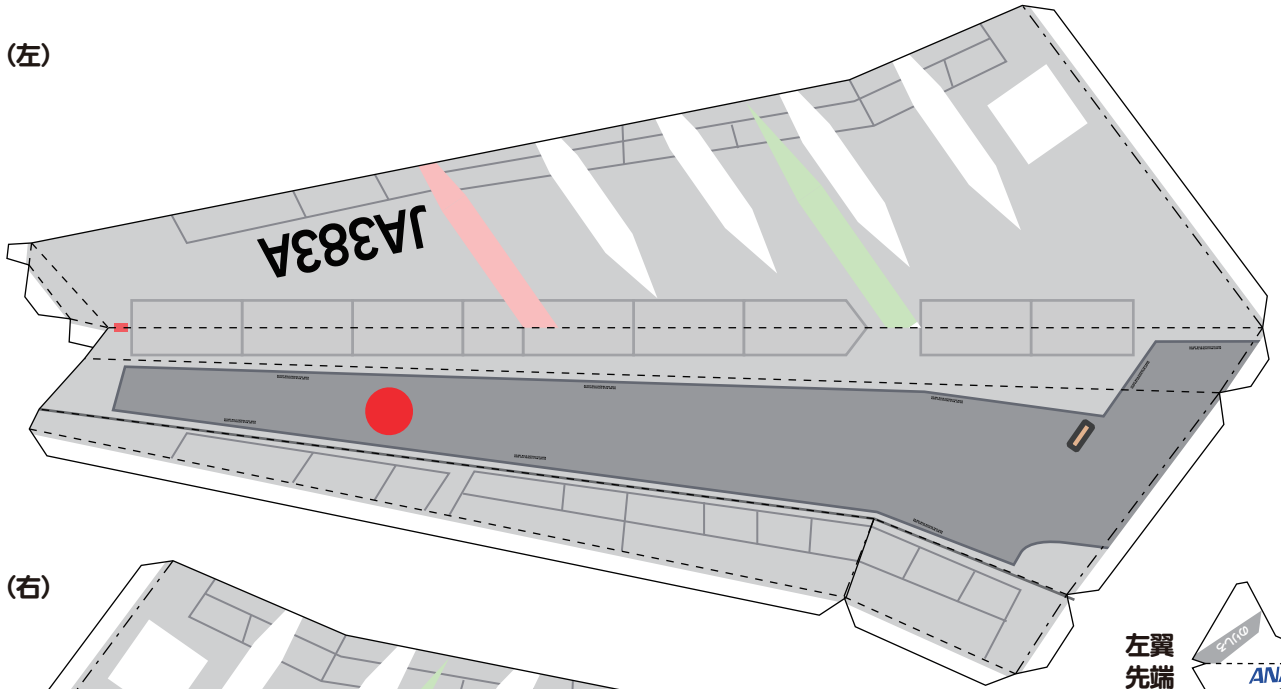

主翼（右）

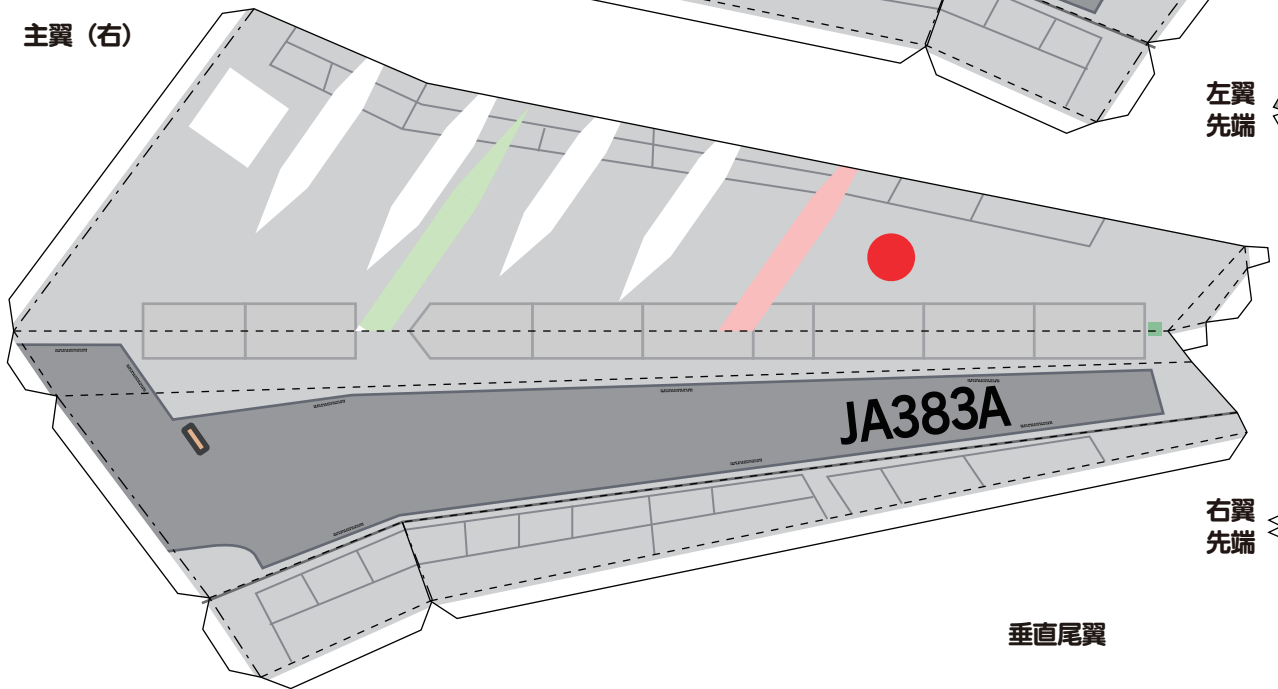

左翼  
先端

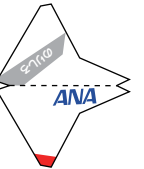

右翼  
先端

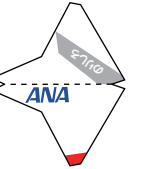

垂直尾翼

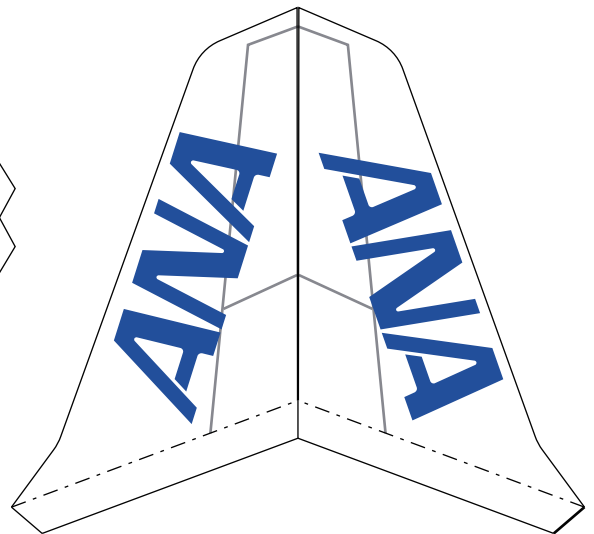

水平尾翼

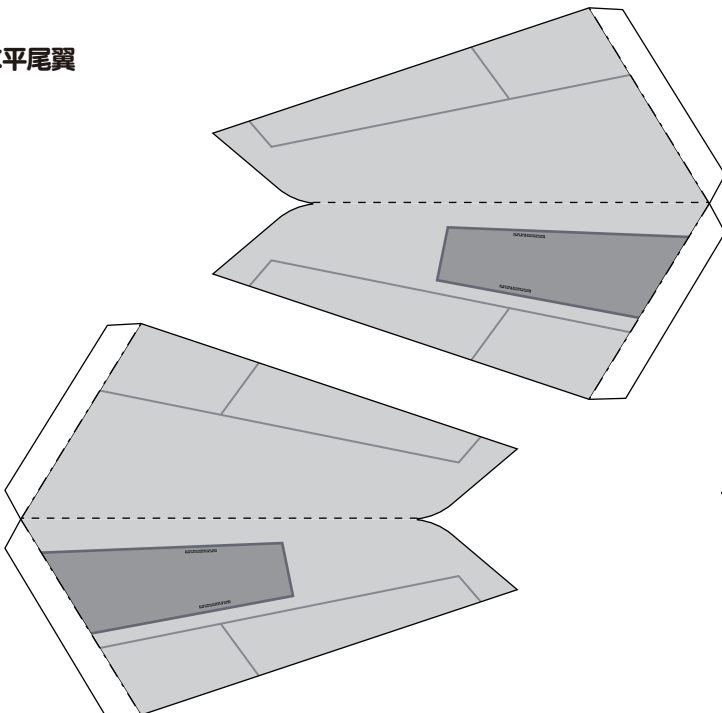

----- 山折り  
- · - · - 谷折り

# エンジンまわり

## エンジン 支え

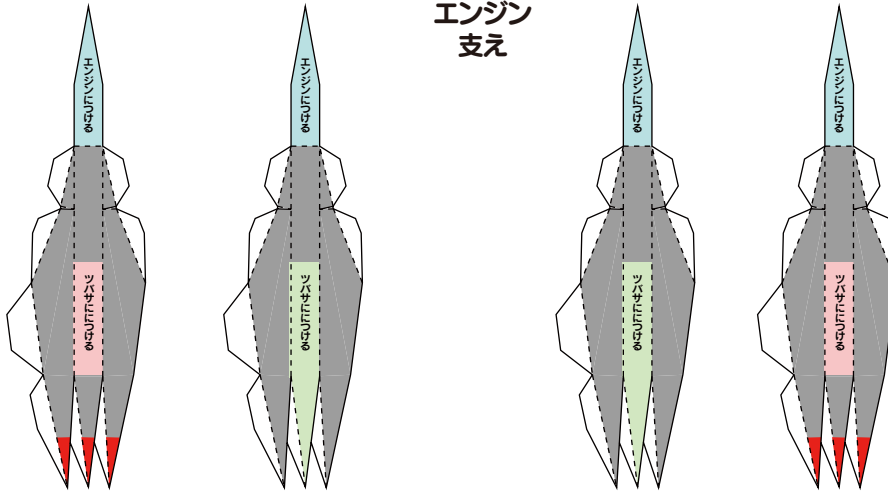

## エンジン左翼 (のりしろが上になる)

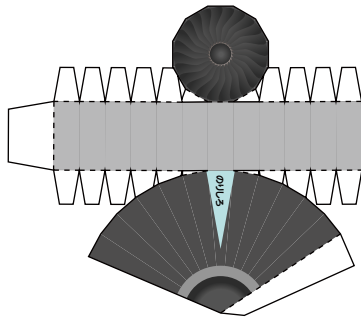
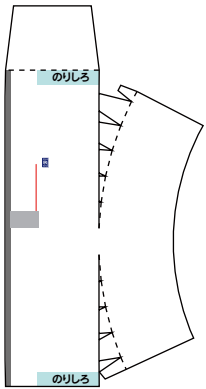

## エンジン右翼 (のりしろが上になる)

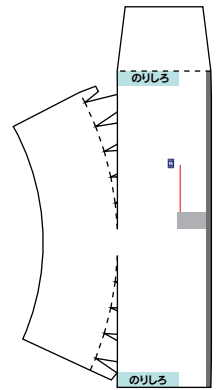
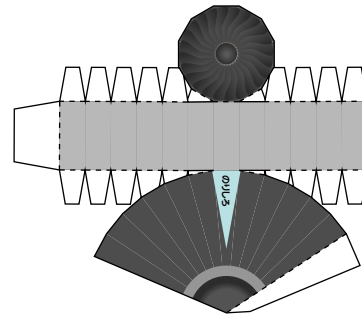
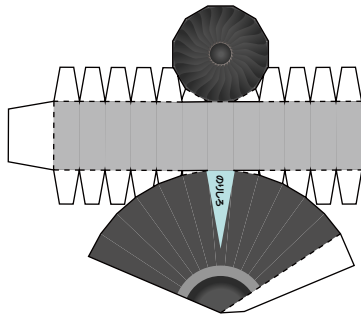
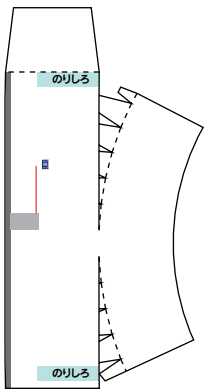
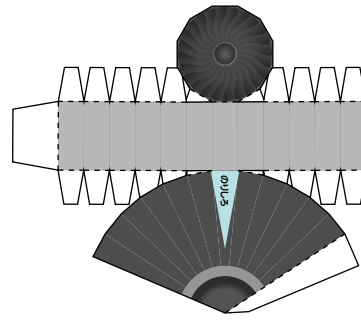
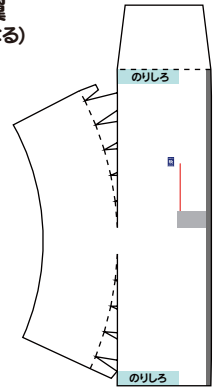

## フェアリング

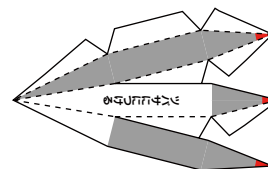
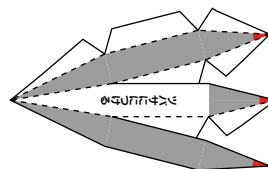
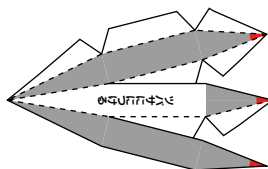
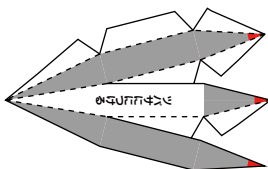
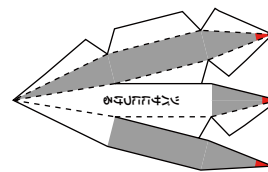
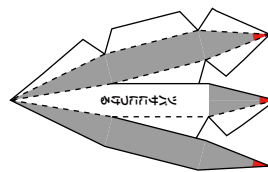
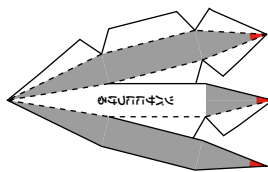
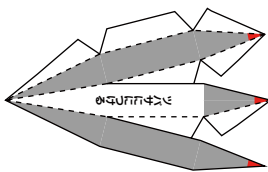

# 胴体 (サンセットオレンジ)

## コックピット

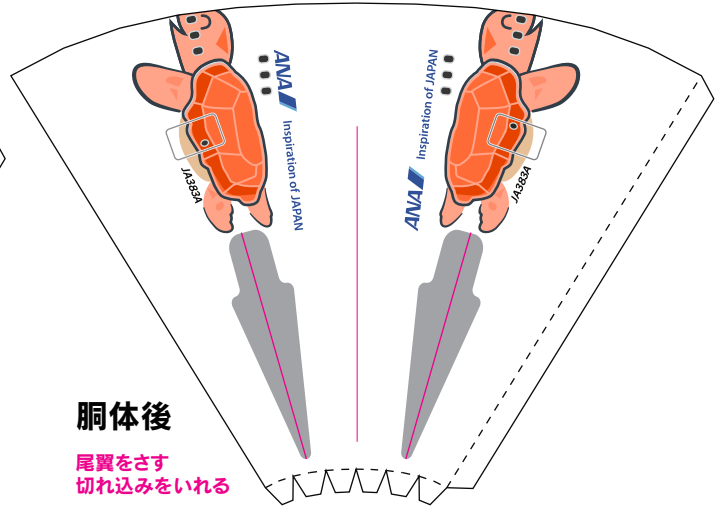
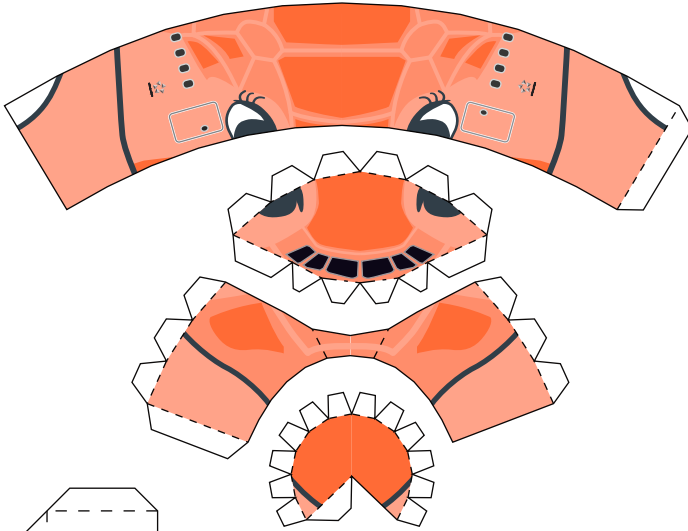

## 胴体後

尾翼をさす  
切れ込みをいれる

## 胴体上

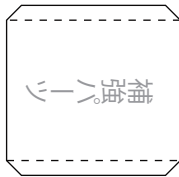
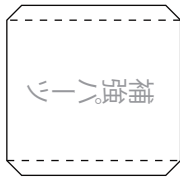
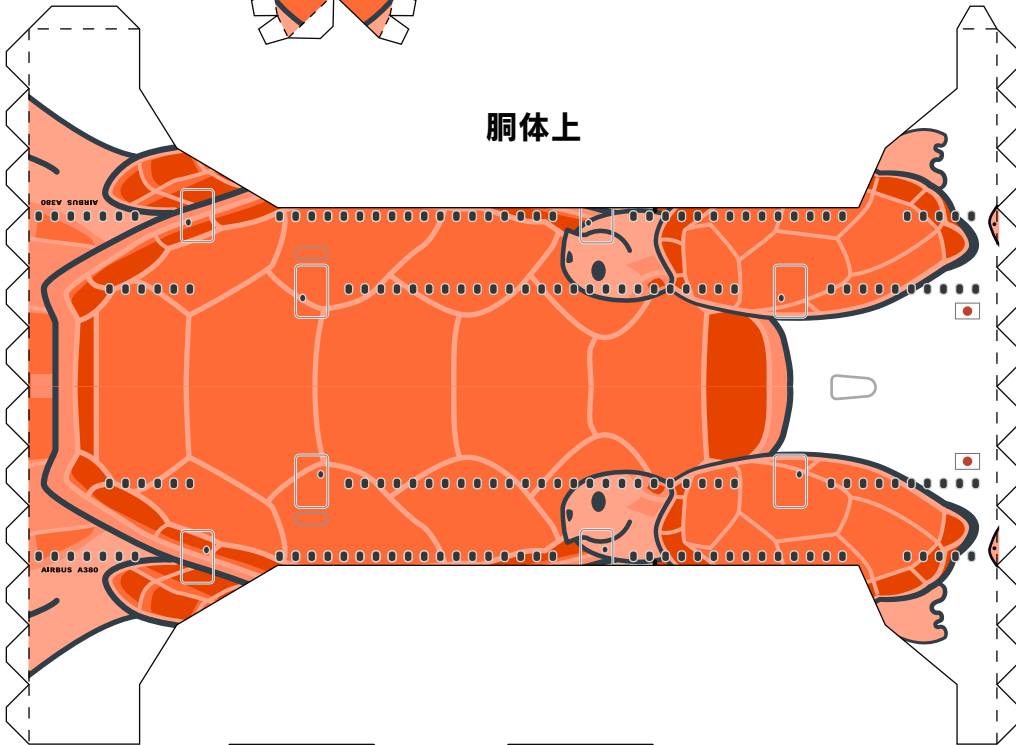

## 胴体下の補強パーツ

## 胴体下

